

Raphaelite PM30/7K MC-Transformer

This is not the result of a scientific measurement, just DIY-Information to choose the desired MC-Transformer

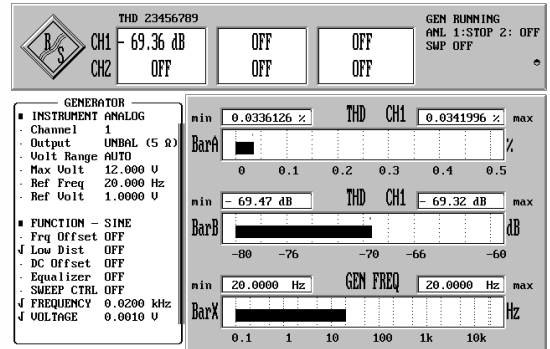

Input: 1.0mV_{RMS}/5Ω + Cable 50pF Output: 47kΩ/100pF + Cable 50pF (no Impedance Correction, no Zobel-Network)

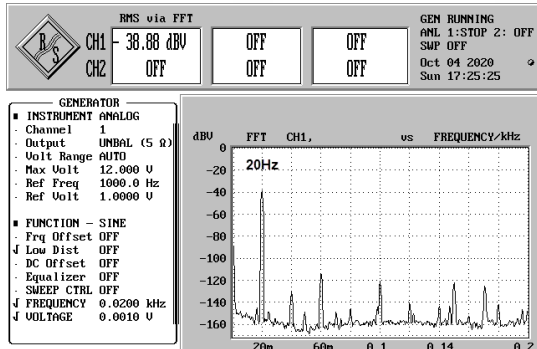
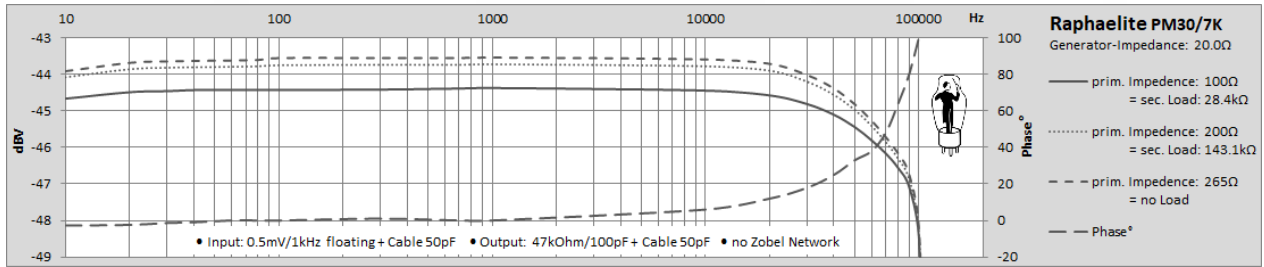
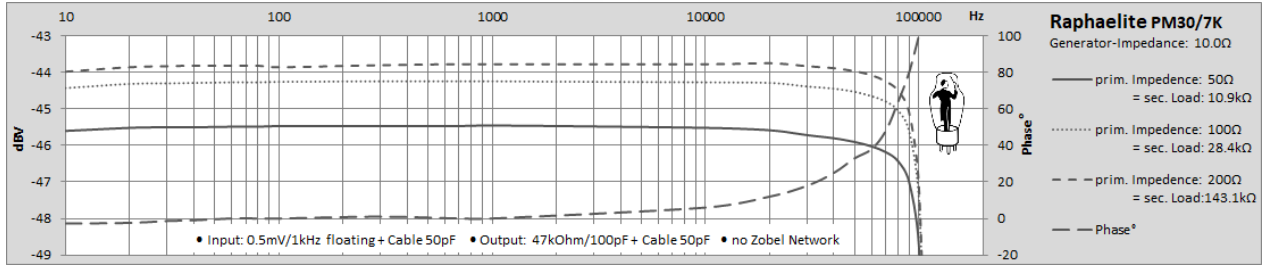
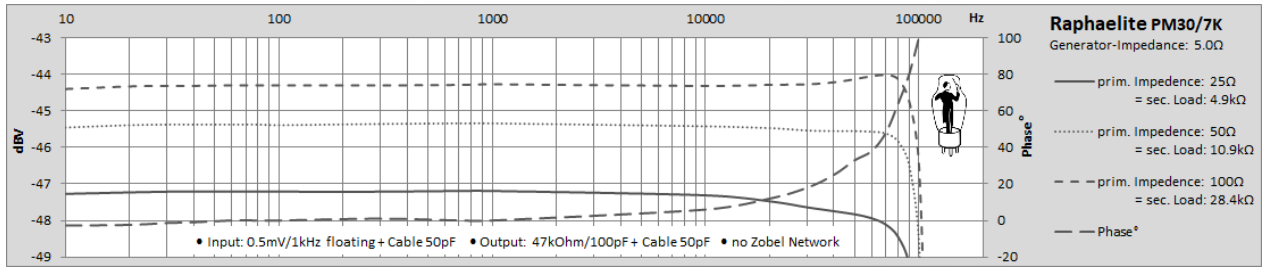
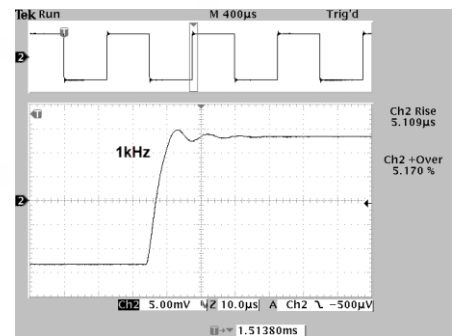
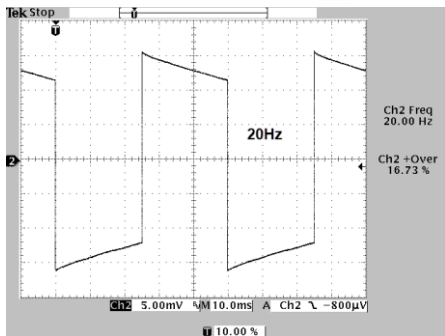

Input: 1.0mV_{RMS}/15Ω + Cable 50pF Output: 47kΩ/100pF + Cable 50pF (no Impedance Correction, no Zobel-Network)

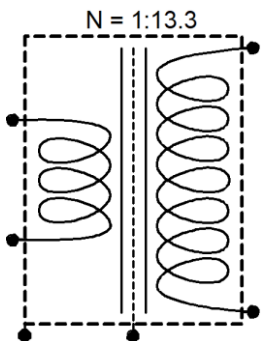

- Turns Ratio (N): 1:13.3
- Prim. Inductance: (L_p): 1.30H/100Hz (Output open)
- Noise-Shield between prim./sec. Windings
- Case-Screw for Grounding
- THD: 20Hz ~0.034%
- 1kHz ~0.002%
- 10kHz ~0.001%

