

Audio Note Step Up Kit MC-Transformer

This is not the result of a scientific measurement, just DIY-Information to choose the desired MC-Transformer

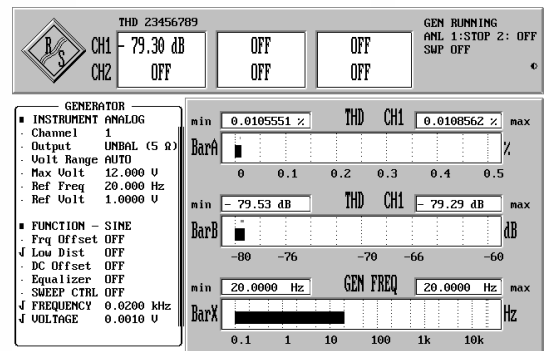

Input: 1.0mV_{RMS}/5Ω + Cable 50pF Output: 47kΩ/100pF + Cable 50pF (no Impedance Correction, no Zobel-Network)

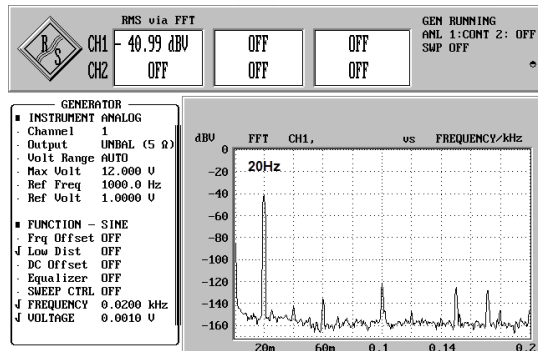
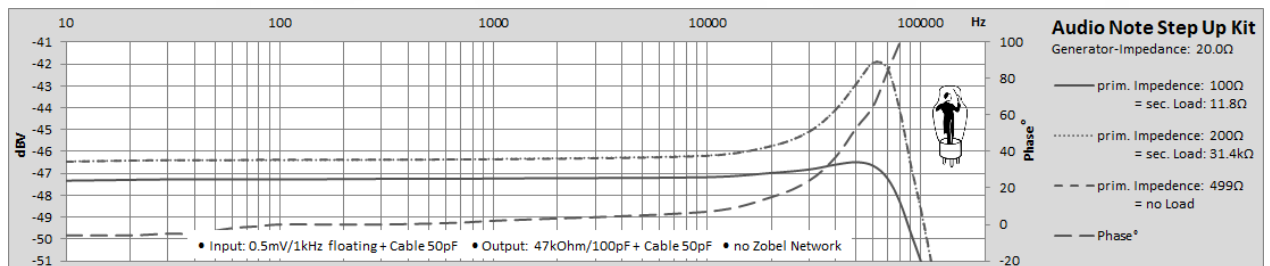
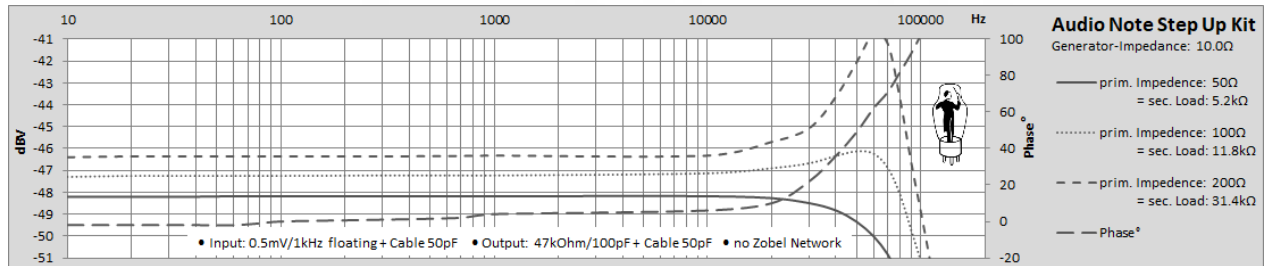
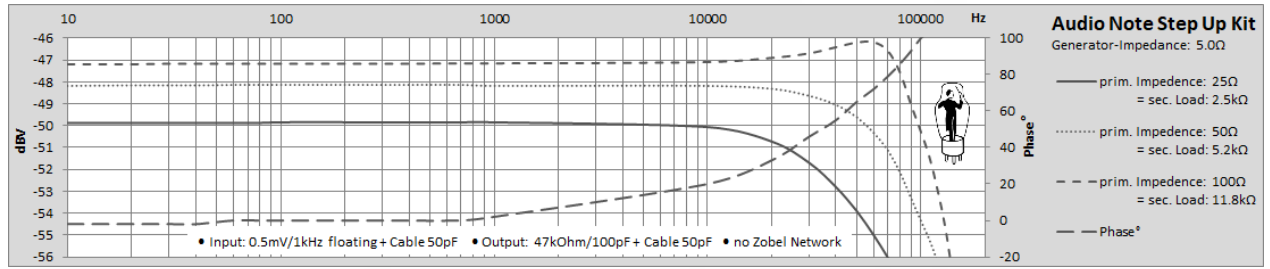
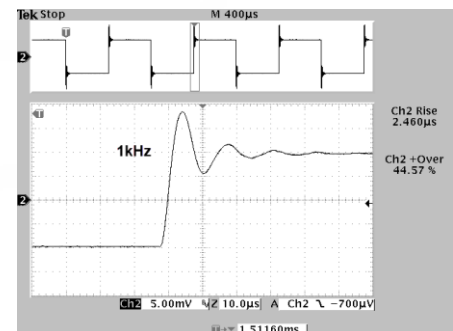
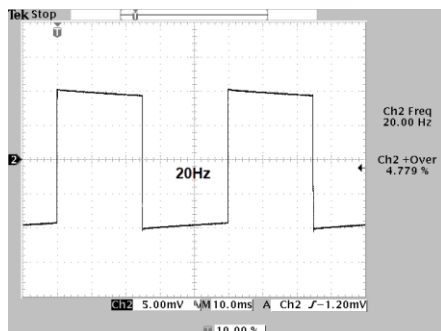

Input: 1.0mV_{RMS}/15Ω + Cable 50pF Output: 47kΩ/100pF + Cable 50pF (no Impedance Correction, no Zobel-Network)

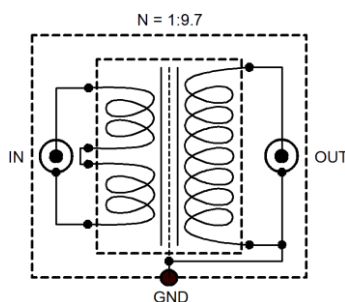

- Turns Ratio = 1:9.7
- Turns Ratio: 1:10 or 1:20 possible
- Prim. Inductance (L_p): 2.15H/100Hz (Output open)
- Noise-Shield between prim./sec. Windings
- Output-RCA connected to Ground
- Ext. Ground-Connector
- THD: 30Hz ~0.010
1kHz ~0.002
10kHz ~0.001

